

Digital Scanning Laser Vibrometer Scan-Series

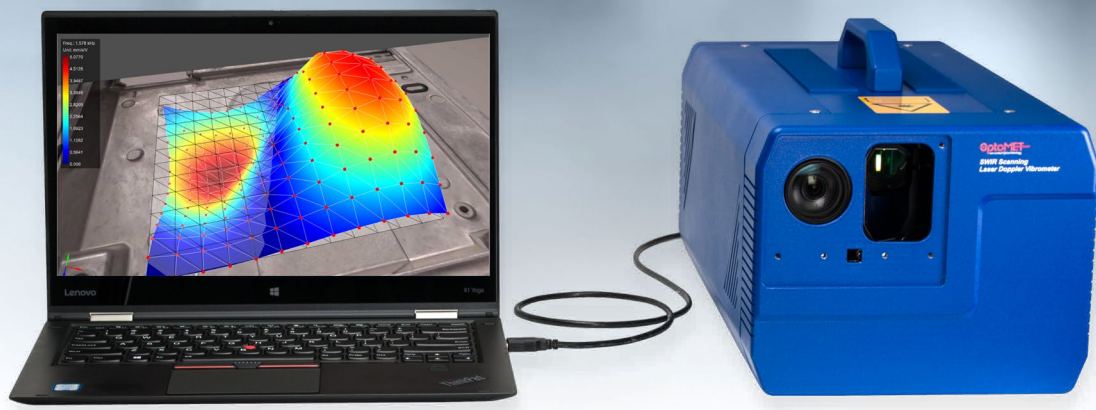

SWIR Scanning Laser Vibrometer

Scanning Laser Doppler Vibrometry is an advanced measurement technique for the visualization of vibrations on the surface of nearly any object. Scanning Laser Vibrometer can measure and visualize vibration shapes and eigenmodes, capture the propagation of surface waves, validate FEM models, characterize vibration processes, and determine modal parameters.

HIGHLIGHTS

- Excellent signal level
- Very compact
- Easy to operate
- Highest accuracy and resolution
- High-speed vibrations up to 30 m/s
- Long-distance measurements



IMAGING VIBRATION MEASUREMENT

The Scan-Series combine the superior signal quality of SWIR laser vibrometry with the informative value of imaging methods by scanning the object under test on a flexibly definable point grid. Different measurement surfaces, wider coverage, and measuring ranges are the key to new fields of application.

Scanning vibrometry makes it possible to test entire workpieces automatically in one measurement process without contact or any influence on the object. Thus, scanning vibrometry enables the capture of local resonances and global vibration modes with the lowest effort.

Applications

● Acoustics

- Automotive industry: Optimization of car door, automotive transmission, brakes, motor, NVH testing...
- Consumer market: Development of household appliance, electronic toothbrush, washing machine...
- Optimization of deflection shapes in loudspeaker, musical instruments...

● Structural Dynamics

- Automotive industry: Modal analysis, FE-model validation...
- Aviation and Aerospace industry: Airplane components, turbines...
- Material Research: non-destructive evaluation of material properties, material defect analysis...



Example applications:



Automotive industry



Aerospace industry

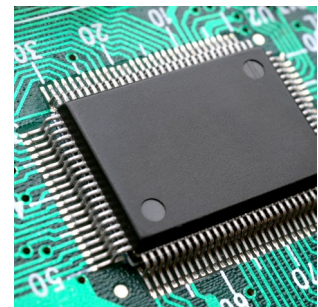

Electronics

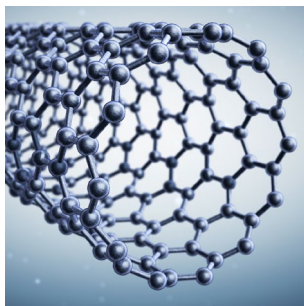

Material research & testing



Toolmaking and Mechanical Engineering

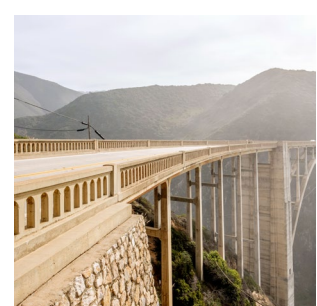

Civil Engineering

Making Measurements

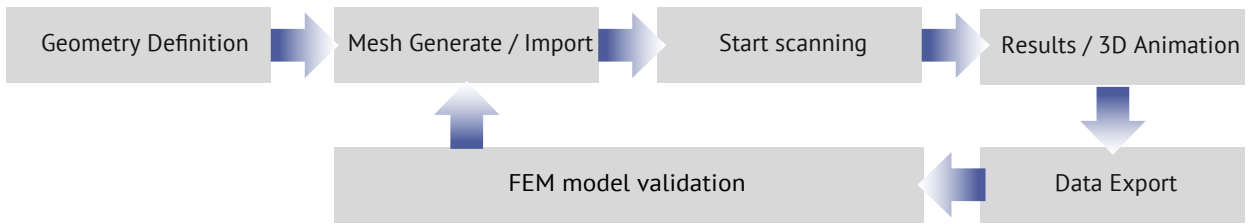

Set up

- Geometry definition
- Mesh generation / import
- Setup of the data acquisition / generator system

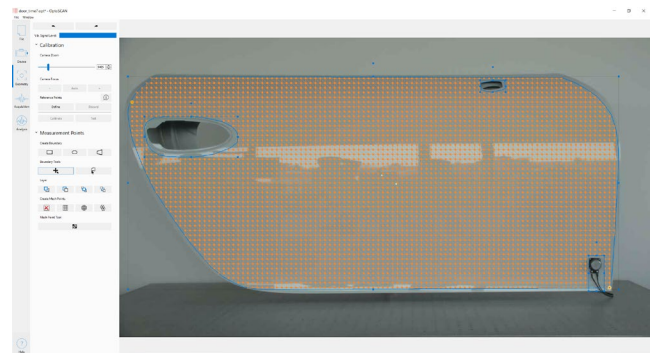

Automatic Scan

- The whole grid is automatically scanned by the laser beam.
- making measurements at each grid point
- Time response and frequency response of each point and reference signals are displayed in real time during the scan.

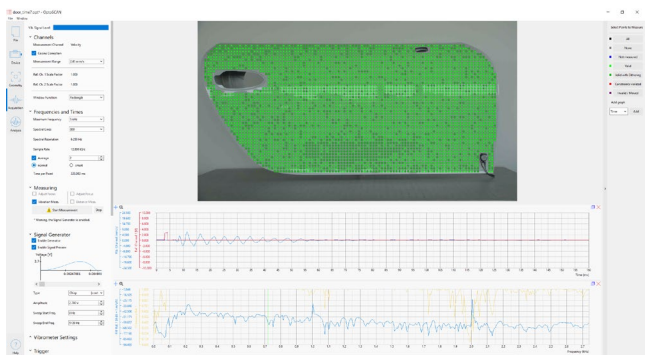

Visualization / Analysis

- 3D Animation to display your ODS (Operation deflection shape)
- Modal analysis
- Data export
- FEM model validation

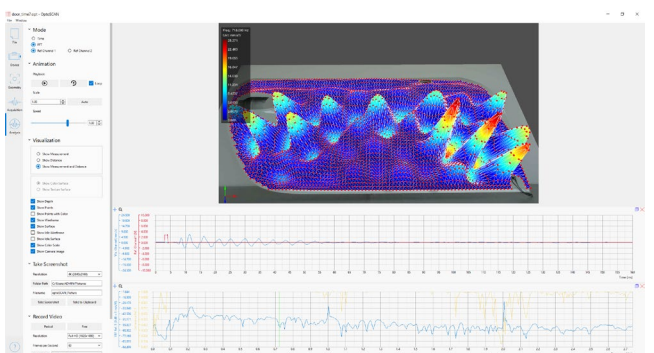

Technical Data

Measured Quantities – Performance Parameters

Max. Frequency	Max. ² Velocity	Best Vel. ¹ Resolution	Max. ^{2,3,4} Displacement	Best Disp. ^{1a} Resolution	Max. ^{2,3,4} Acceleration	Best Accel. ¹ Resolution
25 MHz ⁴	30 m/s	1.7 nm s ⁻¹ /√Hz	±122.5 mm	0.05 pm /√Hz	78.4 Mg	1.8 μg /√Hz

General Measurement Specifications

Measured quantities	Velocity, displacement, acceleration
Frequency bandwidth ²	0 Hz - 25 MHz ⁴
Max. velocity ²	30 m/s
Velocity measurement ranges ²	15
Signal processing	Digital (FPGA based)
Source impedance	50 Ohm
Analog signal output	5× BNC, ±2 V (or ±10 V on request): - Velocity, displacement ³ , acceleration ³ , signal generator - Data rate: 160 MSamples/s @ 16-bit
External Trigger	Digital external trigger in/out via SMB
Filter	High-pass filter*: off / 10 / 20 / 40 / 80 / 160 / 320 / 640 Hz 1.28 / 2.56 / 5 / 10 / 20 / 40 / 80 / 160 kHz Low-pass filter: off / 2.5 / 5 / 10 / 20 / 50 / 100 kHz Tracking filter: off / slow / fast
Integrated signal generator	- 2 x signal generator (optional 3 x, 4 x, 5 x) - Preset standard and user-defined signal forms (sine, chirp, gaussian, ...) - Import of arbitrary functions as text or audio wave-files

Measurement Specifications – Scanning Operation Mode

Scan angle	50° × 40°, resolution < 0.001°, stability < 0.001°/h
Max. scan points/s	> 50
Scan point density	Up to 512 × 512 scan points
Camera & Camera PC-Interface	CCD-Picture capture & live display: Full HD 1080p, 30x optical zoom, horizontal viewing angle: 63.7°(wide end) to 2.3°(tele end), USB 3.0
Digital Signal Output & PC-Interface	1 Gbit RJ45 Ethernet: - Digital data acquisition- and analysis software <i>OptoSCAN</i> ⁵ - Digital remote control of device settings
BNC analog inputs	Measurement input, 2 x reference input (optional 4 x, 6 x, 8 x) 24-bit A/D converter per channel support for IEPE (Integrated Electronic Piezoelectric) inputs
Geometry unit	Measure distances to Objects and their geometry
Sample size	Min. < 1 mm ² , max. > 10 m ²

¹ The Resolution is defined as the signal amplitude (rms) corresponding to a signal-to-noise ratio (SNR) of 0dB with 1 Hz spectral resolution at 50 % f_{max} of smallest measurement range.

^{1a} The Resolution is defined as the signal amplitude (rms) corresponding to a signal-to-noise ratio (SNR) of 0dB with 1 Hz spectral resolution.

² Actual specifications depend on the configured decoder.

³ Optionally available

⁴ $f > 100$ kHz using internal signal generator. f_{max} : 10 – 25 MHz, v_{max} = 1 m/s.

⁵ Standard included: Detailed program features listed below.

* With displacement decoder

Measurement Specifications – Single-Point Operation Mode

Measuring ranges ²	15 (velocity), 19 (displacement), 15 (acceleration)
Digital Signal Output & PC-Interface	1 Gbit RJ45 Ethernet: - Data rate: 1 GBit/s (max. 80 Msample/s, up to 32-bit) - Digital data acquisition- and analysis software <i>OptoGUI</i> ⁵ - Digital remote control of device settings

Optical Specifications

Working distances	250 mm ... 100 m (Geometry Unit: 250 mm ... 30 m) With Coaxial Unit: 111 mm ... 1 m With Close-up Unit: <6.5 mm ... 54 mm
Laser wavelength	Measurement laser: 1550 nm Target laser: 510-530 nm
Laser safety class	Measurement laser: output power: <10 mW, class 1 Target laser: output power: <1 mW, class 2
Lens	LR, focal length: 100 mm
Focusing	Auto-, remote-, and manual focussing

Beam Characteristics

Wavelength: 1550 nm

Minimum stand-off distance (without close-up unit): 250 mm

Stand-off distance ^{*1}	Spot diameter ^{*2} (1/e ² , typ.)	Depth of focus ^{*3} (typ.)
mm	µm	± mm
250	65	2
500	89	4
1000	141	10
1500	190	18
2000	242	30
2500	293	44
5000	530	142

^{*1} Measured from the front of the scanning vibrometer

^{*2} With each additional meter stand-off distance 94 µm are added to the spot diameter

^{*3} For 3 dB signal reduction

With close-up unit:

Stand-off distance ^{*4}	Spot diameter (1/e ² , typ.)	Depth of focus ^{*3} (typ.)
mm	µm	± mm
54	13	0.1
50	14	0.1
45	14	0.1
40	15	0.1
35	16	0.1
30	18	0.2
25	20	0.2
20	22	0.2
15	23	0.3
10.6	25	0.3
6.5	26	0.3

^{*4} Measured from the front of the close-up unit

General Device Specifications

User interface output	Color screen 3.5" + 20 segment LED bargraph
User interface input	Touch screen, knobs with push-button, key switch (power)
Operating temperature	0 to 40°C
Storage temperature	-10°C to 65°C
Relative Humidity	max. 80%, non-condensing
Dimensions	Length × width × height (excluding handle): 450 x 224 x 180 mm
Weight	12 kg
Power supply	110 - 240 V AC (50-60Hz) or 12 V DC, 60 W (typical)
Portable Operation	Possible
Portable power supply	12 V DC portable charger ³
Calibration interval	Every 24 month (recommended)

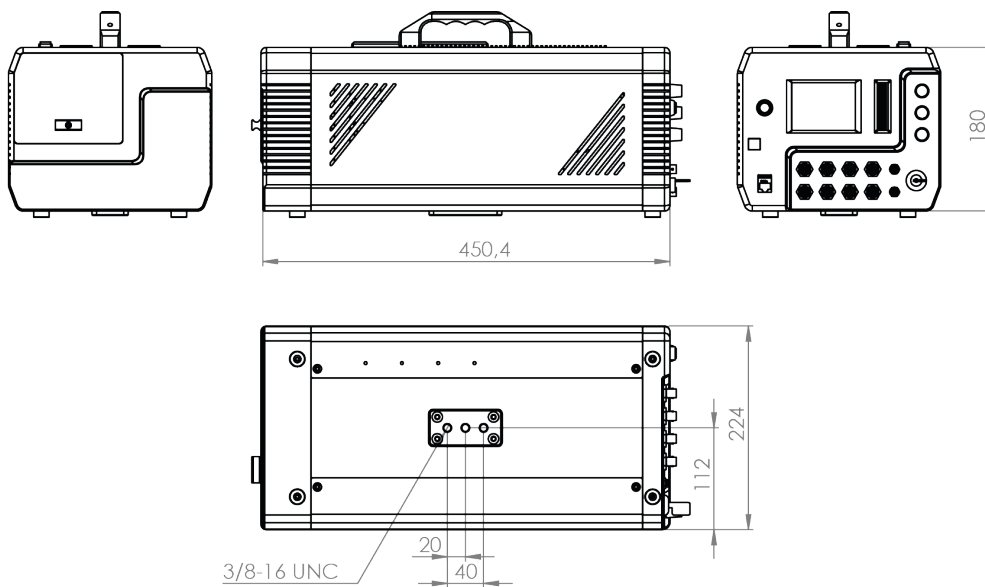

Laser product label

DO NOT STARE INTO BEAM Class 2 Laser Product

Laser CLASS 1: invisible, $\lambda = 1550$ nm, output power: < 10 mW

Laser CLASS 2: visible, green laser beam, $\lambda = 510-530$ nm,
output power: < 1 mW



Model Options - Decoders^{6,7}

Overview Model Options and Characteristics of the standard included Scanning Decoder^{6,7}

Model (Decoder) ^{6,7}	Description	Measuring Ranges ⁶	Max. Velocity	Frequency Bandwidth -Scan
Basis	Versatile model with high resolution. ⁹	8	5 m/s	0 Hz – 100 kHz
Sense	Smallest measurement range ± 2.45 mm/s and highest resolution. ¹⁰	11	5 m/s	0 Hz – 1 MHz ⁴
Sense Speed	Sense configuration with extended velocity range up to 12 m/s.	12	12 m/s	0 Hz – 1 MHz ⁴
High Speed	Supports measurements up to high velocities.	11	25 m/s	0 Hz – 2.5 MHz ⁴
Ultra High Speed	Supports measurements up to highest velocities.	12	30 m/s	0 Hz – 2.5 MHz ⁴
HF	Supports measurements up to highest frequencies.	9	12 m/s	0 Hz – 10 MHz ⁴
Master	The all-rounder: Includes all Sense, High Speed, and High Frequency features.	14	25 m/s	0 Hz – 10 MHz ⁴
Master+	Enables measurements with highest frequencies	14	25 m/s	0 Hz – 25 MHz ⁴
Master++	Enables measurements with highest frequencies and velocities	15	30 m/s	0 Hz – 25MHz ⁴

Characteristics of the Decoders for Single-Point Operation Mode^{6,7}

Decoder ^{6,7,14}		Measuring Ranges ⁶	Smallest Range ^{11,12,13}	Largest Range	Frequency Bandwidth
D-VD-1N	S	8	± 24.5 mm/s	± 5 m/s	0 Hz – 500 kHz
-DD-1N	O	19	± 122.5 nm	± 122.5 mm	
-AD-1N	O	8	± 392 g	± 1.6 Mg	
D-VD-2N	S	11	± 2.45 mm/s	± 5 m/s	0 Hz – 1 MHz
-DD-2N	O	19	± 122.5 nm	± 122.5 mm	
-AD-2N	O	11	± 3.9 g	± 3.2 Mg	
D-VD-2N-12	S	12	± 2.45 mm/s	± 12 m/s	0 Hz – 1 MHz
-DD-2N-12	O	19	± 122.5 nm	± 122.5 mm	
-AD-2N-12	O	12	± 3.9 g	± 7.6 Mg	
D-VD-3N	S	11	± 24.5 mm/s	± 25 m/s	0 Hz – 2.5 MHz
-DD-3N	O	19	± 122.5 nm	± 122.5 mm	
-AD-3N	O	11	± 392 g	± 39.2 Mg	
D-VD-3N-30	S	12	± 24.5 mm/s	± 30 m/s	0 Hz – 2.5 MHz
-DD-3N-30	O	19	± 122.5 nm	± 122.5 mm	
-AD-3N-30	O	12	± 392 g	± 39.2 Mg	
D-VD-4N	S	9	± 24.5 mm/s	± 12 m/s	0 Hz – 10 MHz
-DD-4N	O	19	± 122.5 nm	± 122.5 mm	– 25 MHz ³
-AD-4N	O	9	± 392 g	± 76.8 Mg	
D-VD-5N	S	14	± 2.45 mm/s	± 25 m/s	0 Hz – 10 MHz
-DD-5N	O	19	± 122.5 nm	± 122.5 mm	
-AD-5N	O	14	± 3.9 g	± 78.4 Mg	
D-VD-5N-25	S	14	± 2.45 mm/s	± 25 m/s	0 Hz – 25 MHz
-DD-5N-25	O	19	± 122.5 nm	± 122.5 mm	
-AD-5N-25	O	14	± 3.9 g	± 78.4 Mg	
D-VD-5N-30	S	15	± 2.45 mm/s	± 30 m/s	0 Hz – 25 MHz
-DD-5N-30	O	19	± 122.5 nm	± 122.5 mm	
-AD-5N-30	O	15	± 3.9 g	± 78.4 Mg	

Software

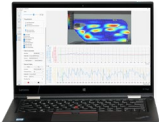
	OptoGUI – Measurement & Analysis Software for data acquisition, analysis, and remote control when using the single-point operation mode. Live animation of measured time and frequency data.	O
	OptoSCAN – Measurement & Analysis Software for data acquisition, analysis, and remote control in scanning operation mode. Animation of measured time data, various analysis functions, and the frequency response function of the scanned surface.	S

OptoGUI software includes

Remote control	Remotely control all vibrometer settings via ethernet.	S
Read-out	Read out data via ethernet with up to 80 MS/s	S
Time data	Live animation of measured vel. / disp. / accel. data	S
Export data	Export time data as .csv, .h5, .wav or .mat files	S
Fourier-Transformation	-Real-Time Fast Fourier Transform -up to 536 Mio. FFT lines	S
Peak identification	Automatically identify signal peaks in the frequency spectrum	S
Spectrogram	Show a live Spectrogram of the FFTs of the ongoing measurements	S
Fourier boundaries	Limit live FFT-calculation to certain time ranges of the time data	S
Signal trigger	Trigger your measurement with the vel., disp., or accel. signal	S
External trigger	Trigger your measurement with an external TTL signal (3.3 V)	O
Multiple traces	Record and recall multiple traces of the vel./disp./accel. time data	S
Arbitrary signal generator	Import file formats: .csv ASCII- or .wav audio files Pre-defined signals: sine, rectangle, chirp, random, ...	O

S: Standard included

O: Optional included

⁶ For details see decoder data-sheets.

⁷ Variations from displayed models available on request.

⁸ Exact measuring ranges listed in the identically named single-point velocity decoder data-sheets (D-VD-1N, ...-2N, ...-2N-12, ...-3N, ...-3N-30, ...-4N, ...-5N, ...-5N-25, ...-5N-30)

⁹ Best velocity resolution: $12 \text{ nm s}^{-1}/\sqrt{\text{Hz}}$

¹⁰ Best velocity resolution: $1.7 \text{ nm s}^{-1}/\sqrt{\text{Hz}}$

¹¹ Best velocity resolution: $1.7 \text{ nm s}^{-1}/\sqrt{\text{Hz}}$

¹² Best displacement resolution: 0.05 pm

¹³ Best acceleration resolution: $1.8 \mu\text{g}/\sqrt{\text{Hz}}$

¹⁴ Decoder for HeNe laser scanning vibrometer on request

OptoSCAN software includes

Remote control	Remotely control all vibrometer settings via ethernet	S
Software architecture	64-bit, multithreaded, fast-responsive software architecture	S
Offline analysis	Analysis of data in offline post-processing	S
Individual Scan Points	Freely chose measurement geometry and individual point positions	S
Distance sensor	Measure the 3-dimensional geometry of your object and the absolute distance to the vibrometer.	O
Arbitrary signal generator	Import file formats: .csv ASCII- or .wav audio files Pre-defined signals: sin, rectangle, chirp, random, ...	S
Camera	Live video stream to monitor the measurement progress	S
Frequency functions	Calculation of FRF, FFT, Auto-Spectrum, Cross-Spectrum, Coherence	S
ODS (operating deflection shape)	3D-animation of mode shapes at selected frequencies	S
Time analysis	Time representation, analysis and animation. Seamlessly switching between frequency and time representation.	O
Heatmap of FRF amplitude/phase	2D-Heatmap of the amplitude and phase of the frequency response function of the measured velocity, displacement or acceleration response	S
Heatmap of FFT amplitude	2D-Heatmap of the FFT of the measurement (vel./disp./accel.) channel and all reference channels	S
Heatmap of time data RMS	2D-Heatmap of the root mean square of the time data	S
Heatmap of coherence	2D-Heatmap of the coherence between measurement and reference channels	S
Speckle-Tracking & point-wise autofocus	High-speed autofocus and configurable speckle-tracking for automatic increase of measurement data quality	S
Modal analysis	Analyze dynamical properties of the scanned structure	O
UFF-Interface	Multithreaded export of ODS data, time data, geometry data, all frequency functions, and data of reference channels	S
Audio-file export	Export of time data as .wav audio-files	S
Video export	Export animations of time data (wave-propagation) and selected mode-shapes as high resolution video file	S
Record Video	Resolution: Full HD (1920 x 1080), HD (1280 x 720) Recording Setup: - Period: Predefined number of recorded periodes - Free: Free hand 3D scene recording - Tracking Shot: User predefined 3D scene point of views with camera panning	S
Data processing	Digital filtering, signal averaging, FFT windows (including rectangle, exponential, Hanning, etc.), real-time integral or differential, display phase, real, imaginary, frequency response function (FRF), etc.	S
FFT lines	Up to 536 Mio.	S
Export data as:	.uff, .hdf5, .mat, and .wav files	S



Accessories

^S Standard included, ^O Optional available

Transport Case	Stable and waterproof Peli case for safe storage and transport of vibrometer External dimensions (L x B x H): 62,5 x 49 x 35 cm	S
Coaxial Unit	Brings the measurement laser and the camera onto the same optical axis.	O
Close-up Unit	For measurements of small objects at the shortest distances of a few mm	O
Protection window	Protects the scanning unit against dust, wind and acoustic excitation at high sound pressure levels.	O
Mobile Battery ¹⁵	External battery power bank, portable battery charger. For powering the vibrometer when performing outdoor measurements.	O
Detector Card	Transforming the not-visible infrared light into a spot of visible light.	S
Tripod with fluid head	Precisely align your vibrometer with high quality tripods by Manfrotto	O
Transport Bag	Compact und light transport bag for outdoor-measurements	O
Ring Light	For illumination of small test objects. Requires Close-up Unit.	O
Mirror Set	For measurements in difficult-to-access areas. The mirror set comprises 4 front Surface mirrors.	O

¹⁵ Adapter cable for different recommended battery models available

Maintenance Specials

Warranty

Warranty	12 months	S
Warranty extension	Extension of standard warranty to 24 months	O

Software Updates

Software maintenance	Free software updates within warranty period	S
Extended maintenance	Additional extension of software updates by 12+ months	O

Hardware Maintenance

Hardware Maintenance	Free hardware maintenance within warranty period	S
Extended maintenance	Additional extension of hardware maintenance by 12+ months	O
Recalibration & cleaning	Check, cleaning & realignment of optical parts, check of laser output power, perform factory calibration	O

DIGITAL LASER DOPPLER VIBROMETER

optomet.
LASER VIBROMETRY

+

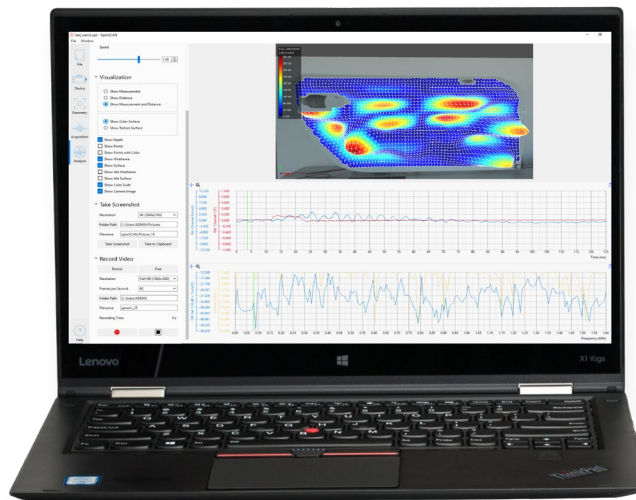
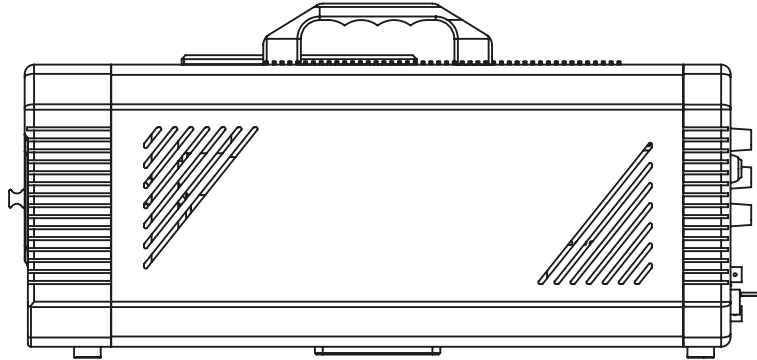

CONTACT US

Optomet GmbH | Pfungstaedter Strasse 92
64297 Darmstadt | Germany
Phone +49(0)6151-38432-0 | sales@optomet.de
www.optomet.com